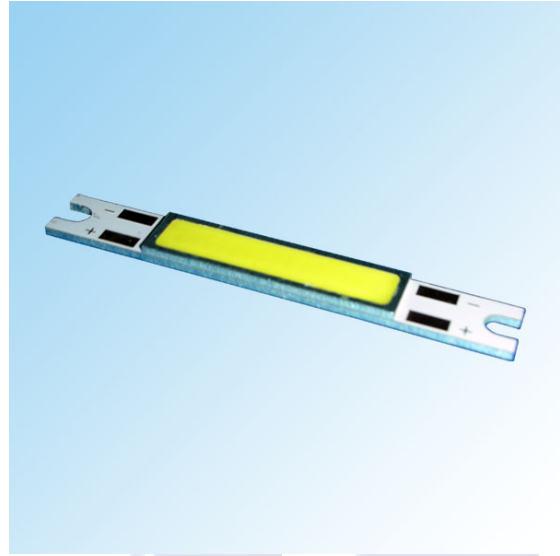

**PRELIMINARY SPEC****HL-LB001D17W-5B5C3 WHITE  
(HL-LB001D17W-5B5C3 白光)****Features (特征)**

- Single Color.  
(单色)
- Illuminant Color: White.  
(发光颜色:白色)
- Emission angle:120Deg.  
(发光角度: 120 度)
- Linear Packaging Design.  
(线性包装设计)
- High Efficiency.  
(高发光效率)
- Low Power Consumption.  
(低功率消耗)
- Long Operating Lifespan.  
(工作寿命长)
- Easy Installation with Screws.  
(螺钉安装便利)
- High Heat dissipation Efficiency.  
(散热性能好)

**Applications (用途):**

- Reading Lamp.  
(台灯)
- Street Lamp.  
(路灯)
- LED Backlight.  
(背光源)
- Energy Saving Lamp.  
(节能灯)
- Decorative and Entertainment Lighting.  
(装饰和娱乐照明)
- Indoor and Outdoor Commercial Lighting.  
(室内和室外广告照明)

**Description (描述)**

Part number (型号)	Dimension (L*W*H) mm (尺寸规格)	Chip (晶片)		Colloid Type (胶体类型)
		Emitter color (发光颜色)	Material (材料)	
HL-LB001D17W-5B5C3	50*7*1.8	White (白色)	InGaN	Yellow Diffuse (黄色发散)

## LED Package Dimensions and Polarity (LED 的封装尺寸和极性)

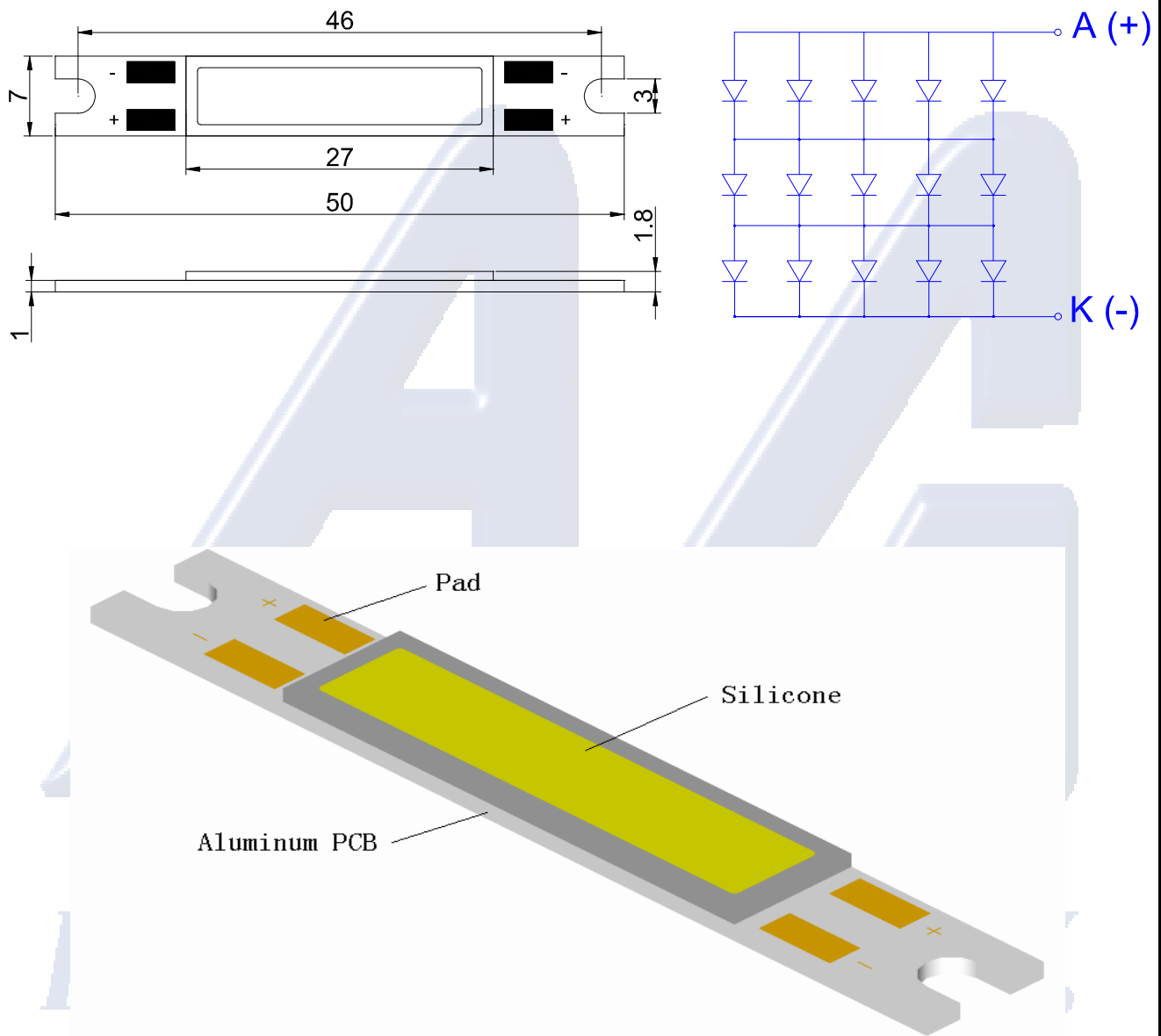

Figure 1: Product Dimension  
(产品尺寸规格)

### Notes:

1. All dimensions are measured in mm.  
(所有尺寸单位: 毫米.)
2. Tolerance:  $\pm 0.2$ .  
(公差:  $\pm 0.2\text{mm}$ .)
3. The temperature of Aluminum PCB dose not exceed  $55^{\circ}\text{C}$ .  
(PCB 板的温度不超过  $55^{\circ}\text{C}$ .)

**Absolute Maximum Rating at T<sub>A</sub>=25°C** (在 25°C 环境下的最大绝对额定值)

Table 1 Absolute Maximum Rating For Product

(表 1 产品的绝对最大额定值)

Parameter(参数)	Symbol(符号)	Rating(White) (数值)	Unit(单位)
DC Forward current (正向电流)	IF	500	mA
Peak plus current (峰值电流)	IFM	1000	mA
Reverse voltage (反相电压)	VR	5	V
ESD Sensitivity (静电灵敏度)	VB	500	V
Power dissipation (功率消耗)	PD	5	W
Junction temperature (结温)	T <sub>j</sub>	125	°C
Operating temperature (工作温度)	Topr	-30~+100	°C
Storage temperature (储存温度)	Tstg	-40~+120	°C
Soldering temperature (焊接温度)	Tsol	260	°C
Manual Soldering time at 260°C(Max) (在 260°C 下手工焊接时间)	--	5	sec

## Notes:

1. Proper current rating must be observed to maintain junction temperature below the maximum at all time.  
(电流额定值要维持在最大结温以下.)
2. LEDS are not designed to be driven in reverse bias.  
(LED 不能设计为反偏驱动.)
3. IFM condition: 0.1ms Pulse width , Duty Cycle=0.25.  
(正向电流的测试条件: 脉宽: 0.1ms,周期: 0.25.)

## Color Temperature Characteristics (色温特性)

Table 2 Color Temperature Characteristics (TA=25°C)

(表 2 25°C 环境温度下色温特性)

Part Number (型号)	Device (发光颜色)	Test Current (测试电流)	Color Temperature (色温)			Unit (单位)
			Min (最小值)	Typ. (典型值)	Max (最大值)	
HL-LB001D17W-5B5C3	Warm white	IF=500mA	2500	--	3800	K
	Neutral white		3800	--	5000	
	Cool white		5000	--	10000	

### Note:

Color temperature measured with the accuracy  $\pm 200\text{K}$ .

(色温的测量精度为 $\pm 200\text{K}$ .)

## Luminous Flux Characteristics (光通量特性)

The following table describes flux of product under various current and different colors.

(下表描述的是在不同电流下不同颜色的产品的光通量.)

Table 3 Product luminous flux characteristics at TA=25°C

(表 3 25°C 环境下产品的光通量特性)

Part Number (型号)	Color (颜色)	Test Current(mA) (测试电流)	Flux (光通量)			Unit (单位)
			Min (最小值)	Typ. (典型值)	Max (最大值)	
HL-LB001D17W -5B5C3	Warm white	500	110	170	--	lm
HL-LB001D17W -5B5C3	Neutral white	500	130	190	--	lm
HL-LB001D17W -5B5C3	Cool white	500	140	210	--	lm

### Note:

Flux is measured with the accuracy of  $\pm 10\%$ . (光通量的测量精度是 $\pm 10\%$ .)

### Typical Electro-Optical Characteristics Curves (典型的光电特性曲线)

#### Forward Voltage vs Forward Current

(正向电压与正向电流关系曲线图)

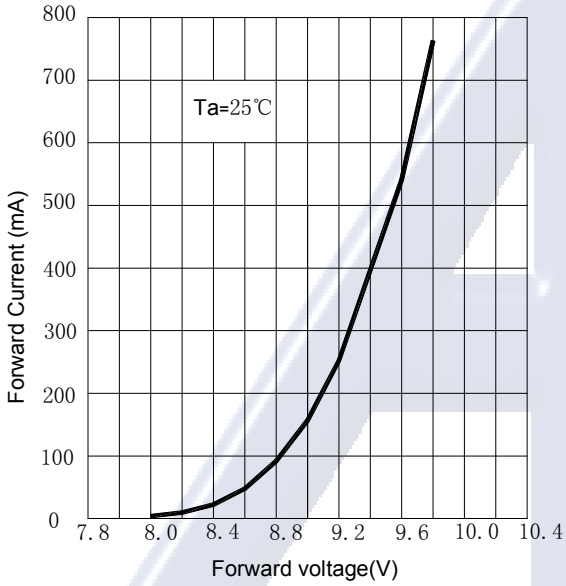

#### Forward Current vs Luminous Intensity

(正向电流与光强关系曲线图)

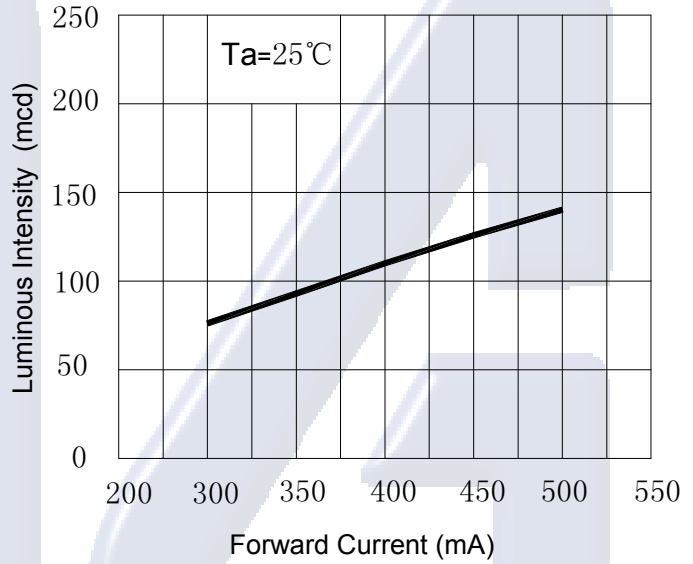

### Spatial Distribution Graph (空间分布曲线图)

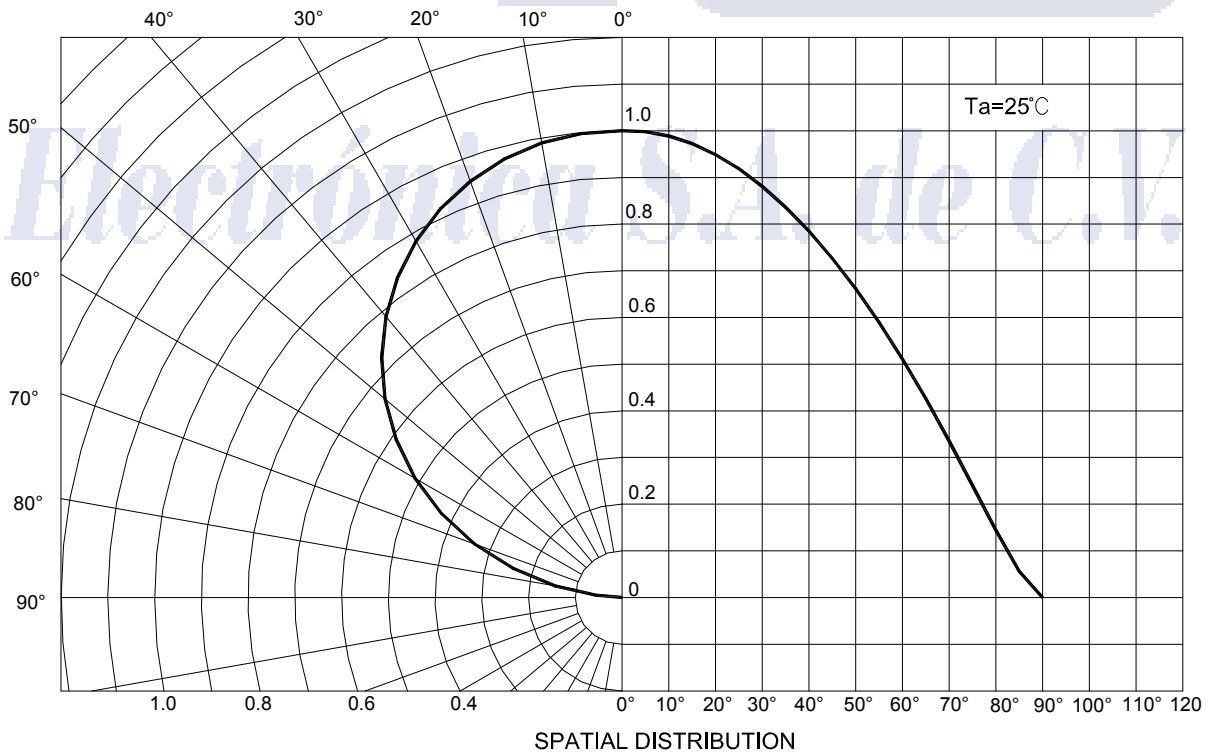

**Emission Angle Characteristics (发光角度特性)**

Table 4 Product's Emission Angle Characteristics (TA=25°C)

(表 4 25°C环境下产品的发光角度特性)

Part Number (型号)	Device (发光颜色)	Test Current (测试电流)	Viewing Angle $2\theta_{1/2}$ (Typ.) (发光角度)		Unit (单位)
			X direction (X 方向)	Y direction (Y 方向)	
HL-LB001D17W- 5B5C3	Warm white	IF=500mA	120	110	Deg
	Neutral white		120	110	
	Cool white		120	110	

**Note:**

$\theta_{1/2}$  is the angle from optical centerline where the luminous intensity is 1/2 of the peak value.

( $\theta_{1/2}$  是指发光强度为峰值光强的 1/2 方向与光源中心法线的夹角.)

**Optical & Electrical Characteristics (光电特性)**

Table 5 Product's Optical and Electrical Characteristics (TA=25°C)

(表 5 25°C环境下产品的光电特性)

Parameter (参数)	Symbol (符号)	Device (发光颜色)	Min (最小值)	Typ. (典型值)	Max (最大值)	Unit (单位)	Test Conditions (测试条件)
Forward voltage (正向电压)	VF	Warm white	--	9.7	10.5	V	IF =500mA
		Neutral white	--	9.7	10.5		
		Cool white	--	9.7	10.5		
Chromaticity Coordinates (色品坐标)	X	Warm white	0.38	--	0.40	--	IF =500mA
		Neutral white	0.36	--	0.38		
		Cool white	0.31	--	0.32		
	Y	Warm white	0.33	--	0.35	--	IF =500mA
		Neutral white	0.36	--	0.39		
		Cool white	0.32	--	0.33		

### Product Thermal Application Information (产品热应用说明)

When assembling on PCB or heatsink carrier, thermal grease should be evenly spreaded with a thickness<100um.

(当把产品焊接在 PCB 板或者散热器上时，PCB 板或者散热器表面要均匀涂上一层散热硅脂，并且散热硅脂的厚度小于 100um.)

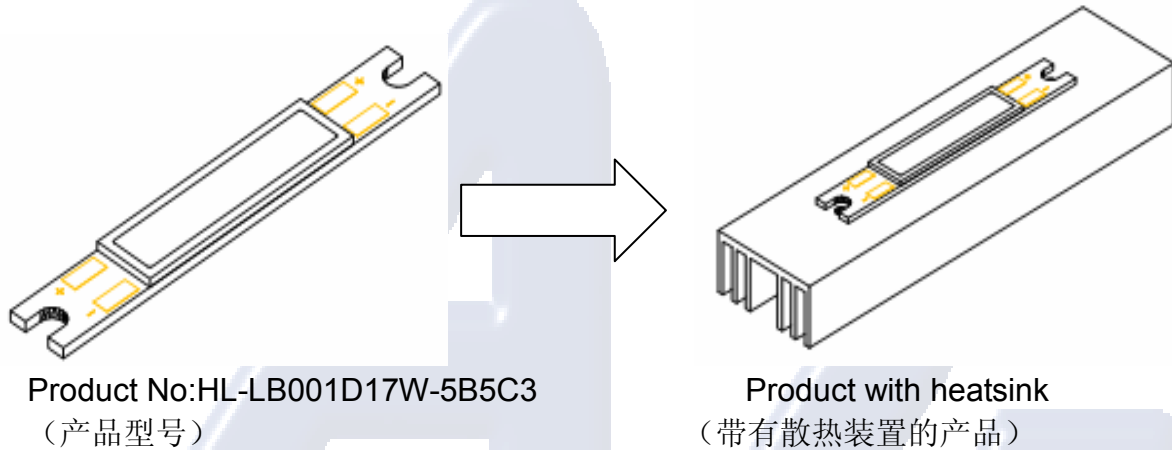

Figure 4 Heatsink application  
(散热装置应用)

### Product Packaging information (产品包装说明)

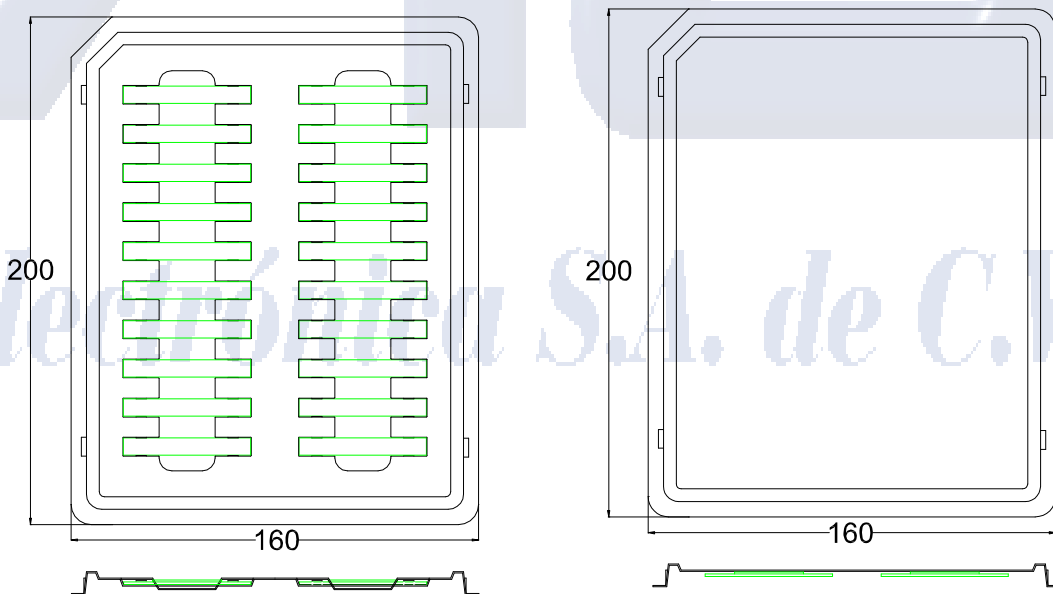

Figure 5 Tray Package dimensions  
(包装盒尺寸)

Note:

1. There are 20pcs emitters in a tray package.  
(每个包装盒有 20 个 LED.)
2. Package storage condition will be limited temperature 20~30℃  
RH 40%~55%.  
(包装存储条件为：温度：20~30℃，湿度：40%~55%.)