

**Philips Optical Storage**

# DATA SHEET

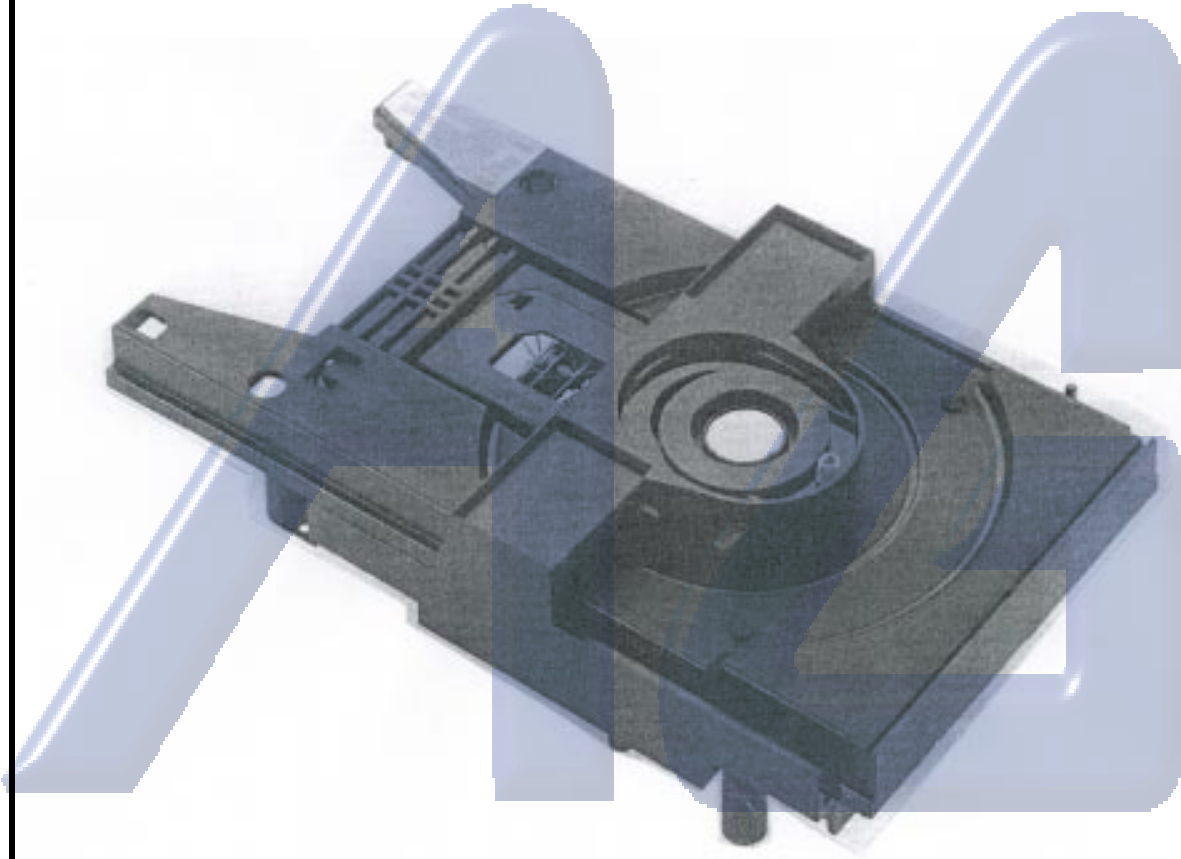

*Electrónica S.A. de C.V.*

**L1210/65/68**

**Tray loaders incorporating  
VAM1202/12 mechanism for 2x Speed**

Product specification  
Version 1.0

MAY 2000

**Philips Components**



**PHILIPS**

## SCOPE OF THIS DOCUMENT

- This document describes the Commercial specification of the tray loader assembly and CD mechanism
- The provisions of this document may be altered upon agreement between both parties
- If any disagreement should arise, these two parties shall meet in good faith to resolve the matter
- Within the range of these specifications, parts are subjected to change without prior notice for technical improvement.
- Please ensure to observe strictly the following, otherwise, PHILIPS may not be able to assume the responsibility for things to happen :
  - \* Always use the mechanism(s) within the conditions given in the specification
  - \* No additional process be given to the mechanism(s)
  - \* Ensure the set containing PHILIPS mechanism(s) is in compliance with the rules and regulations for spurious radiation
  - \* Measure the leakage of laser output from a set containing the mechanism(s) and ensure that the set is in compliance with applicable requirements
  - \* Always adhere to the handling instructions

# *Electrónica S.A. de C.V.*

---

All Rights are reserved. Reproduction in whole or in part is prohibited without the prior written consent of the copyright owner.

The information presented in this document does not form part of any quotation or contract, is believed to be accurate and reliable and may be changed without notice. No liability will be accepted by the publisher for any consequence of its use. Publication thereof does not convey nor imply any license under patent or other industrial or intellectual property rights.

---

## TABLE OF CONTENTS

1.	GENERAL INFORMATION .....	4
2.	SPECIFICATION .....	4
2.1	TEST CONDITIONS .....	4
2.2	SPECIFIED VALUES .....	4
2.2.1	General .....	4
2.2.2	Mechanical .....	5
2.2.3	Electro-mechanical .....	5
3.	ELECTRICAL CONNECTIONS .....	6
4.	APPLICATION INFORMATION .....	6
5.	RELIABILITY .....	6
6.	STANDARDS .....	7
7.	VERSIONS .....	7
8.	HANDLING INSTRUCTIONS .....	8

## TABLE OF FIGURES

FIG. 1:	EXPLODED VIEW .....	9
FIG. 2:	L1210/65/68 PARTLIST .....	10
FIG. 3:	RECOMMENDED WIRING DIAGRAM .....	11
FIG. 4:	OPEN CLOSE SCHEME .....	12
FIG. 5A:	L1210/65 GENERAL DIMENSION (DRAWING 1) .....	13
FIG. 5B:	L1210/65 GENERAL DIMENSION (DRAWING 2) .....	14
FIG. 5C:	L1210/65 GENERAL DIMENSION (DRAWING 3) .....	15
FIG. 5D:	L1210/65 MAX HEIGHTS OF PARTS ON PCB .....	16
FIG. 6A:	L1210/68 GENERAL DIMENSION (DRAWING 1) .....	17
FIG. 6B:	L1210/68 GENERAL DIMENSION (DRAWING 2) .....	18
FIG. 6C:	L1210/68 GENERAL DIMENSION (DRAWING 3) .....	19
FIG. 6D:	L1210/68 MAX HEIGHTS OF PARTS ON PCB .....	20
FIG. 7:	L1210/65/68 TRAY FRONTSIDE DIMENSION .....	21
FIG. 8:	PACKAGING INSTRUCTIONS .....	22
FIG. 9 :	CONTENTS AND PLACEMENT OF LABEL .....	23
APPENDIX 1:	MABUCHI RF-310TA-11400 MOTOR DATA .....	24

## 1. GENERAL INFORMATION

The L1210/65/68 is an assembly of a VAM1202/12 CD-Mechanism and a tray-loader, including suspension and clamping parts.

The L1210/65/68 is delivered with wiring on the loader motor, loader switch and CD-Mechanism.

For specific information on the VAM1202/12 CD-Mechanism (12NC: 9305 022 20212), please refer to the attached product specification.

The assembly is designed for 12 and 8 cm. discs according to the RED BOOK standard. It is applicable only in horizontal position.

The L1210/65/68 are designed to be used in Video-CD applications for 2x speed

## 2. SPECIFICATION

### 2.1 Test conditions

Parameter	Min.	Typ.	Max.	Unit
Ambient temperature	20	25	30	°C
Relative humidity	45		75	%
Air pressure	86		106	kPa
Setting angle horizontal (front to back)	-5	0	5	°
Setting angle horizontal (side to side)	-5	0	5	°

### 2.2 Specified values

#### 2.2.1 General

Parameter	Min.	Typ.	Max.	Unit	Notes
CD-standard					acc. IEC 908
Disk diameter	80		120	mm	

**Philips Optical Storage****Product Specification****Tray loader assembly incorporating VAM1202/12 for 2x Speed****L1210/65/68****2.2.2 Mechanical**

Parameter	Min.	Typ.	Max.	Unit	Notes
Exploded view					See fig. 1 ( Page 9 )
Colour of tray					Black with texture
Dimensions (low mounting) - L1210/65					226 x 131 x 51 mm
Dimensions (high mounting) - L1210/68					226 x 131 x 69 mm
Weight		0.34		Kg	without disc
Tray displacement		148		mm	
Load and eject time		1.7		sec	at 3.5 V
Push tray distance	2	3.5	5	mm	
Force to activate tray			5	N	

Note:

The disc can be removed vertically, without touching any part of the loader or the matching encasing, when the tray is in the fully ejected position.

**Mechanical noise**

Test disc: SBC442

Measuring condition : The ambient noise must be max. 22 dBA (acc. IEC 651). The fixing points of the unit have to be fixed on a steel plate (0.8 x 250 x 400 mm). This plate is supported by a foam rubber, thickness at least 20 mm. The microphone is situated at 100 mm above the turntable motor. No hard reflecting noise materials are allowed in the direct environment.

Load noise	73 dBA RMS hold
excl. technical clicks	53 dBA typ.
Rattling noise	Not allowed

**2.2.3 Electro-mechanical**

Parameter	Min.	Typ.	Max.	Unit	Notes
Open close scheme					See fig. 4 ( Page 12)
Loader Motor type					Mabuchi RF- 310TA-11400
Operating voltage range	3.3		4.0	V	Recommended
For detailed information : see appendix 1 ( Page 24)					

**Loader switch**

Parameter	Min.	Typ.	Max.	Unit	Notes
Current			1	A	
Voltage			16	V Dc	

### 3. ELECTRICAL CONNECTIONS

Recommended wiring diagram - see fig. 3 ( Page 11 )

### 4. APPLICATION INFORMATION

Operational	Temperature range	-10 to +55 °C
	Absolute humidity range	1.5 to 30 gr / m <sup>3</sup>
	Relative humidity range	5 to 90 %
	Condensation	Not allowed
Not Operational	Storage temperature range (packed)	-25 to +55 °C
	Exposure (unpacked)	Max. 70 °C ( 48 hours )
	Relative humidity range	5 to 95 %
	Acceleration during transport	Max 40g during 6 msec, 500 times 3 directions
		Max 60g during 6 msec, 3 times 6 directions
Working position	Horizontal with turntable up	
Built-in conditions	front to back angle	0 ± 10 °
	side to side angle	0 ± 10 °

Note :

After being subjected to the above operational conditions, given a recovery time of 4 hours in 25 °C and no condensation present on the lens, the loader will comply to the specification.

After storage test or burn-in > 250 hours test, given a recovery time of 4 hours in 25 °C and no condensation present on the lens, the CD mechanism is capable to be functional and the substrate current should not deviate more than -30% to +25%.

Serviceability : The loader may be used in the upside-down position. A standard CD will playback and nothing will be damaged. However, the specification is not valid.

It is recommended to make sure that the tray of the L1210/61/63 in the application set is unable to move outwards during transportation of the application set.

### 5. RELIABILITY

Lifetime	
No of cycles (open/close/open)	20000

## 6. STANDARDS

The L1210/65/68 has been designed to comply with safety standards of various countries. However, since its approval depends on the application, this unit is not approved as a unit.

The loader is prepared for the following standards:

IEC 65  
UL 1270  
UL 1492  
UL 1950  
CSA-C22.2 No. 1-M90

The loader is UL recognised (RMNQ2):

UL filenumber: E143838      typenumber: L1210/65/68

The loader has been evaluated by UL for material flammability requirements only, in accordance with the standard for information technology equipment, UL1950.

## 7. VERSIONS

- L1210/65    low mounting tray loader assembly incorporating VAM1202/12, suspension and clamping.
- L1210/68    high mounting tray loader assembly incorporating VAM1202/12, suspension and clamping.

*Electrónica S.A. de C.V.*

## 8. HANDLING INSTRUCTIONS

- Usage and storage in dusty, high temperature and high humidity environments should be avoided.
- To avoid damage to the LDGU by electrostatic discharges, measuring equipment and operators must be grounded during handling (refer to VAM1202/12 CD mechanism specification attached). The user of this unit must take all necessary precautions to avoid ESD (Electro-Static Discharge) failures during handling and assembly of this unit into his end product.
- Contamination of the objective lens will influence the performance. Avoid fingerprints on the lens, handle the mechanism in a clean environment.
- The sledge with lightpath has been adjusted carefully during manufacturing. High forces on this part may damage the unit and have to be avoided.  
**Avoid touching and high forces on this part!! Do not disassemble or readjust!!**
- Safety: The (invisible) laser beam may damage the human eye. Avoid that people can look directly or indirectly into the objective lens when the power is switched on.
- Fast heating up (e.g. by bringing the mechanism from a cold place into a warm and humid room) can result in moisture condensing on the lens, thus influencing the playability for a certain time. Before checking the performance the mechanism should stabilise for at least 4 hours. See also the recovery times mentioned in UAN-D 1590

*Electrónica S.A. de C.V.*

Fig. 1: Exploded view

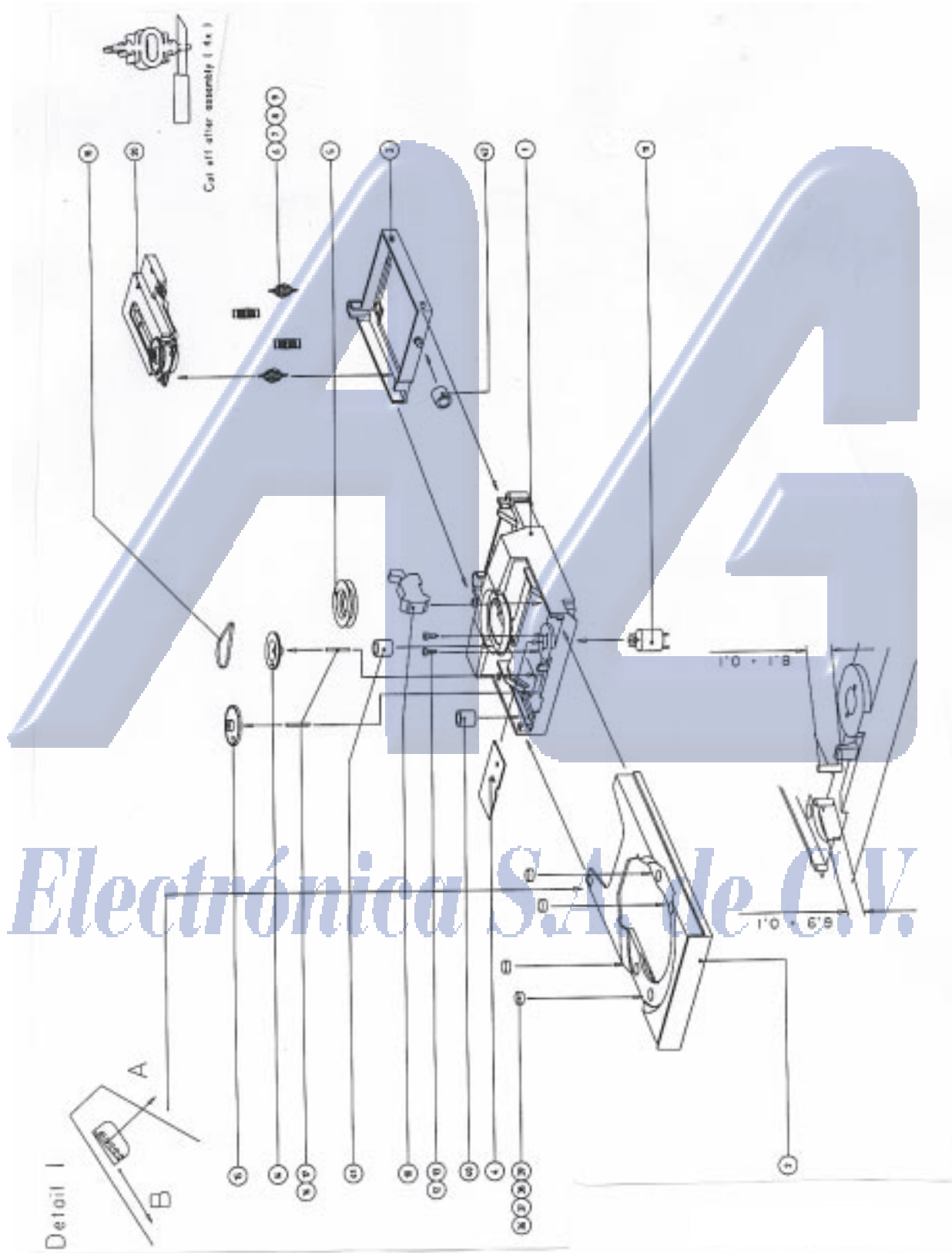

Fig. 3: Recommended wiring diagram

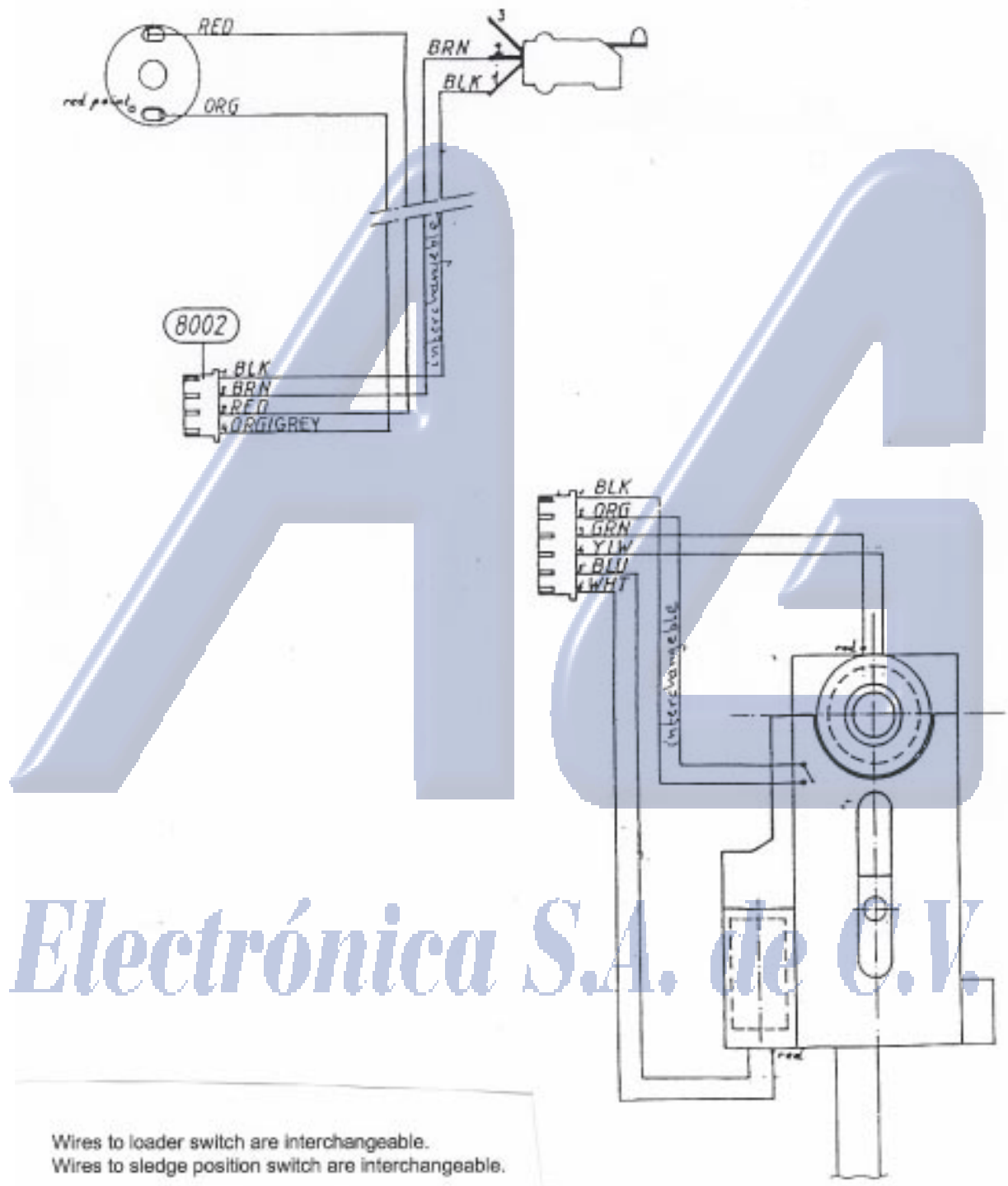
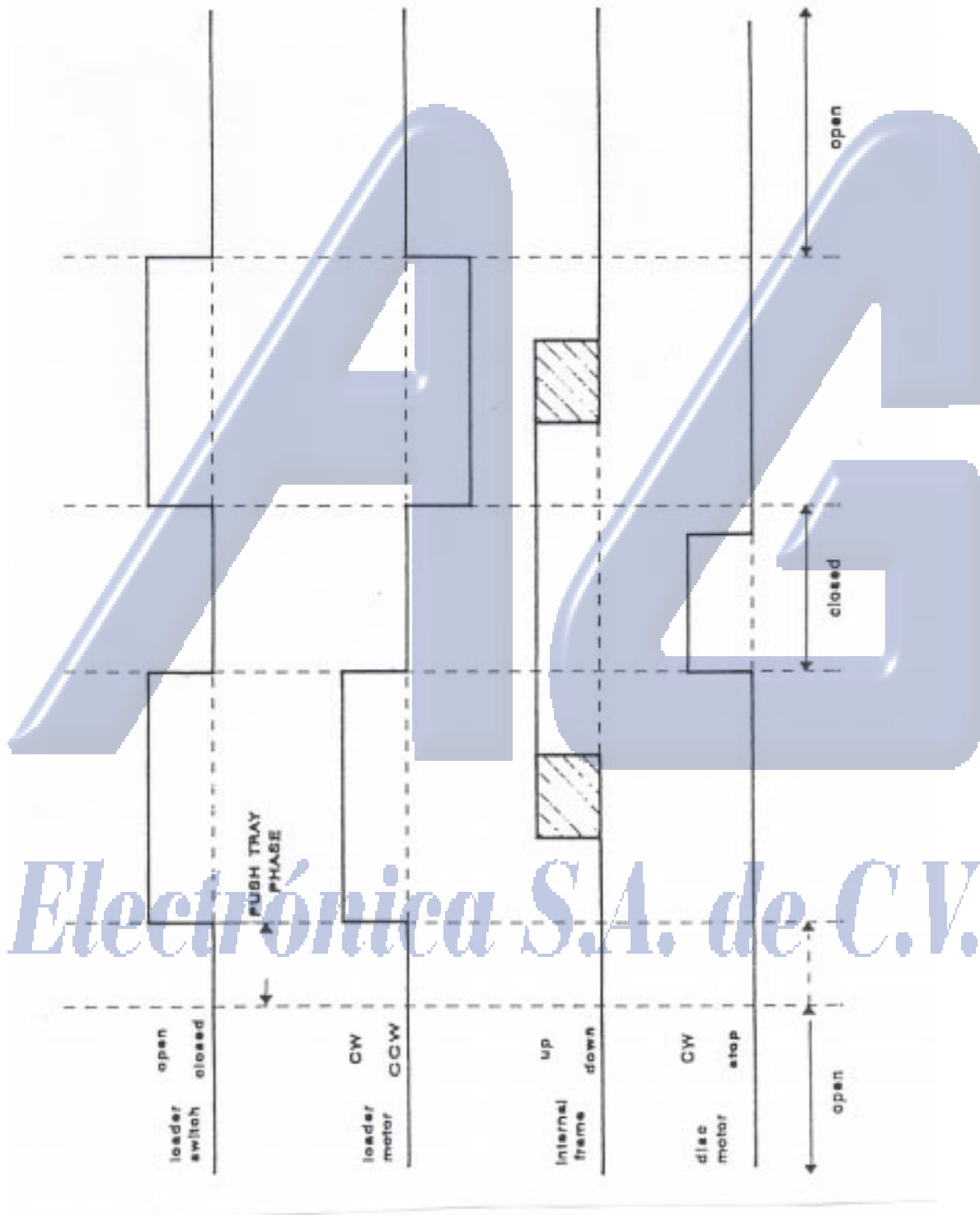

Fig. 4: Open close scheme



*Electrónica S.A. de C.V.*



Fig. 5b: L1210/65 General Dimension (Drawing 2)

FOR INFORMATION ONLY  
Note: Measurements are in mm.

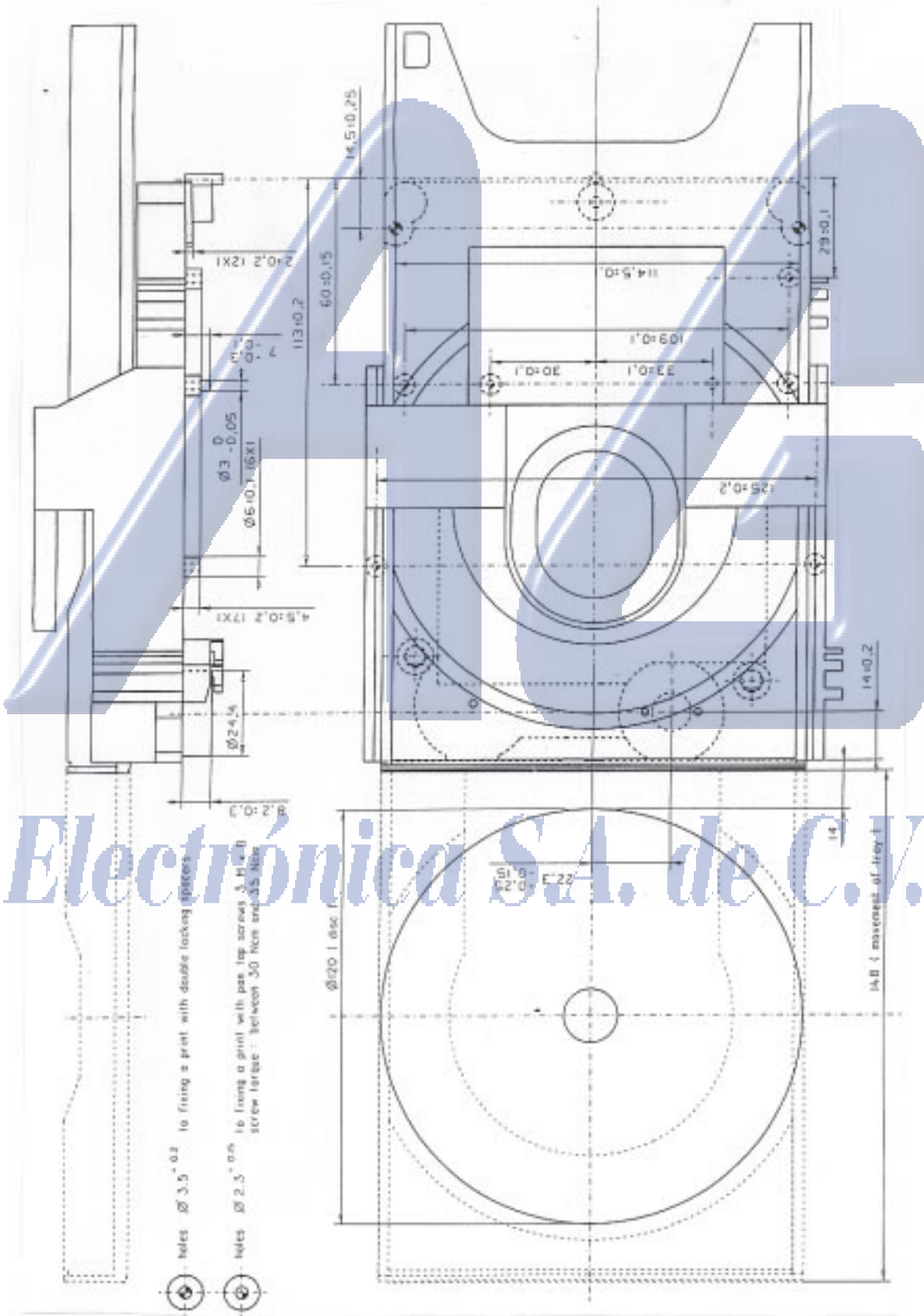

**Fig. 5c: L1210/65 General Dimension (Drawing 3)**

FOR INFORMATION ONLY  
Note: Measurements are in mm.

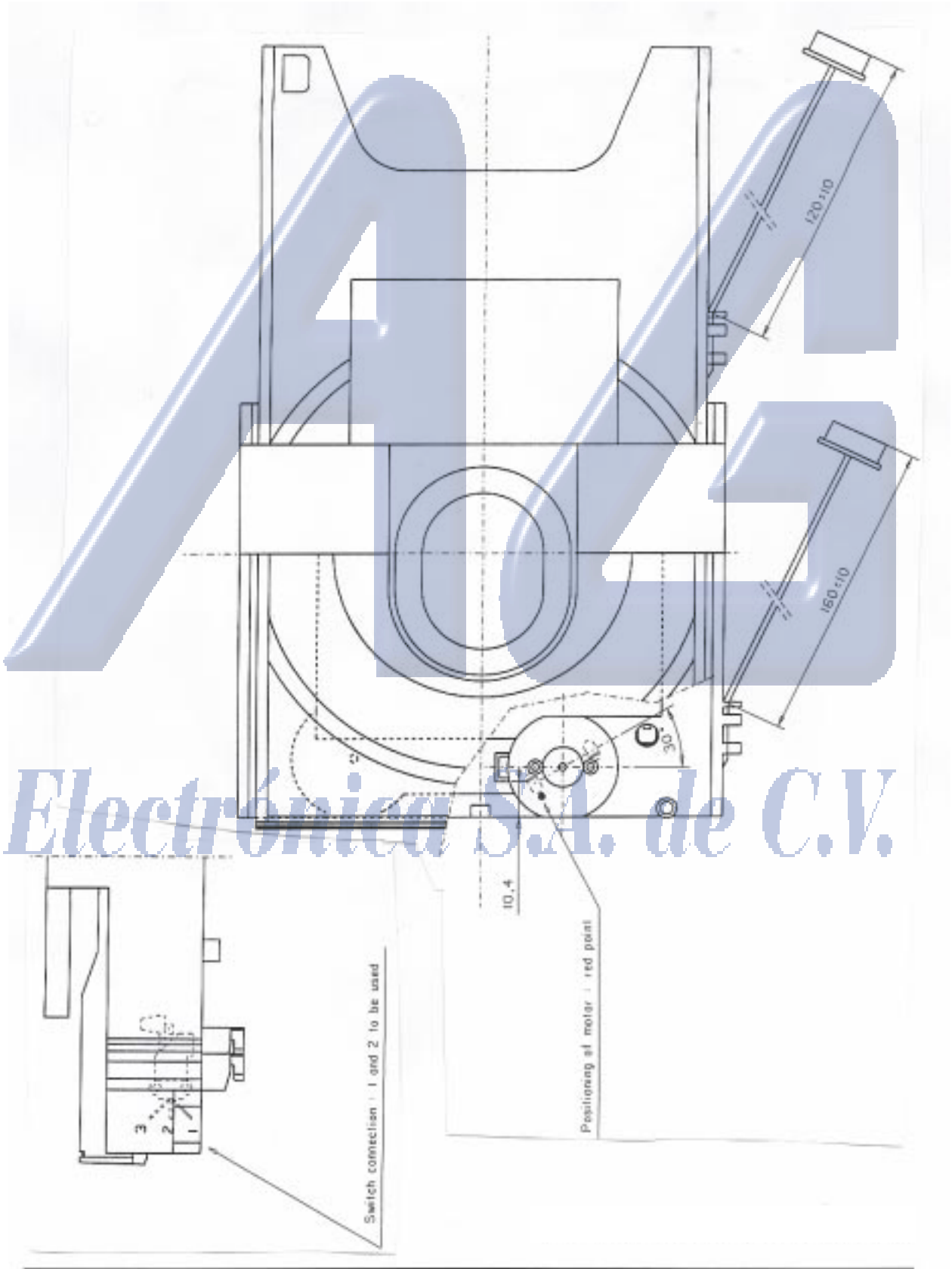
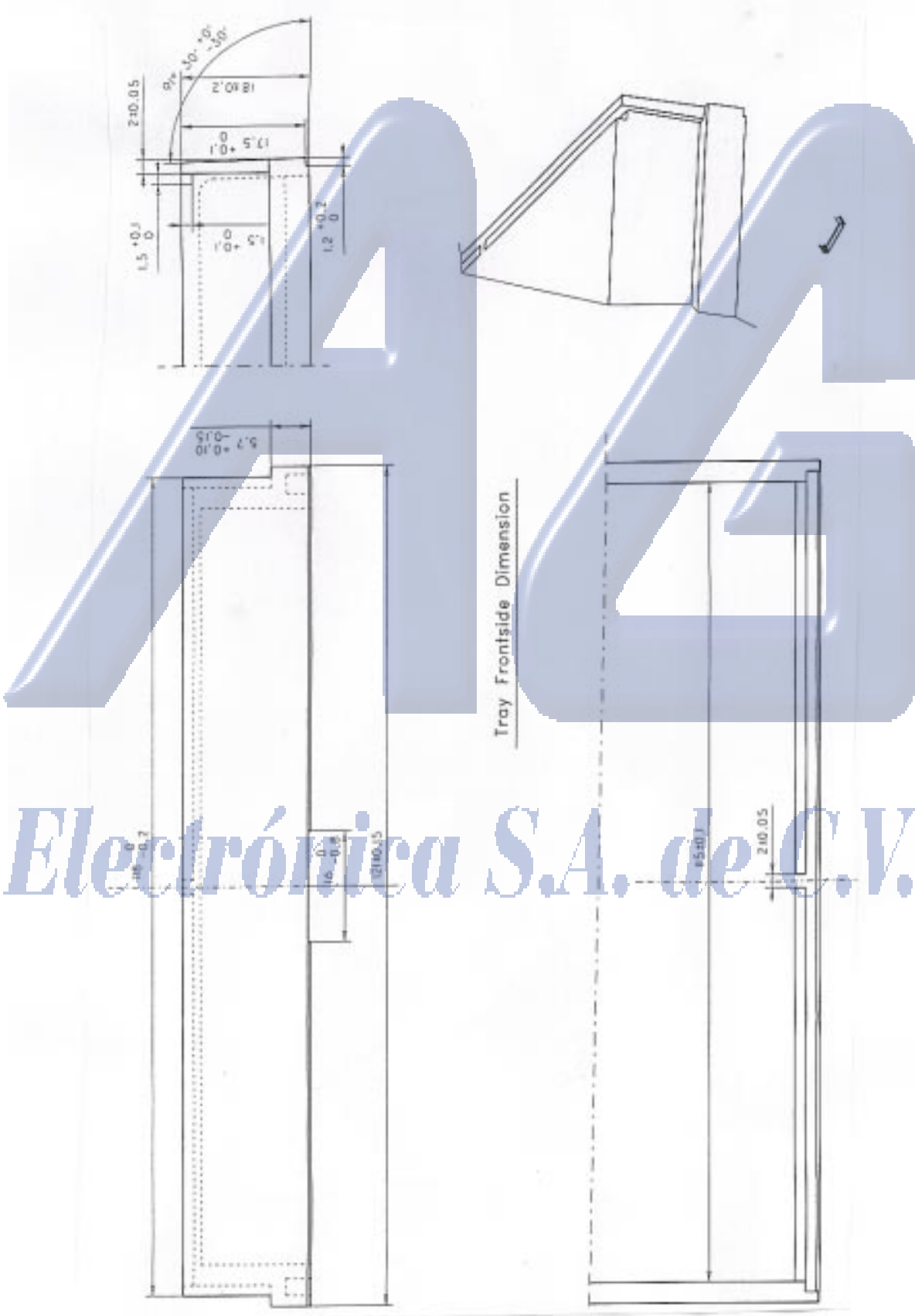



Fig. 7: L1210/65/68 Tray Frontside Dimension

FOR INFORMATION ONLY  
Note: Measurements are in mm.



**APPENDIX 1: MABUCHI RF-310TA-11400 Motor Data**

Note: for information only

**STANDARD OPERATION CONDITION**

<b>Parameter</b>	<b>Min.</b>	<b>Typ.</b>	<b>Max.</b>	<b>Unit</b>	<b>Notes</b>
Rated voltage		5		V Dc	
Working voltage range	1.8		6	V Dc	
Rated load		6		g-cm	

**INITIAL CHARACTERISTIC SPECIFICATION**

<b>Parameter</b>	<b>Min.</b>	<b>Typ.</b>	<b>Max.</b>	<b>Unit</b>	<b>Notes</b>
No load speed at rated voltage	5100	5800	6500	rpm	
Rated load speed at rated voltage	4000	4600	5200	rpm	
Rated load current at rated voltage			135	mA	
No load current at rated voltage			45	mA	
No load starting voltage			0.8	V	
Starting current at rated voltage	390	450	510	mA	
Starting torque at rated voltage	18			g-cm	
Insulation resistance	10			M•	20 °C, 65 % R.H.
Rotor resistance	11			•	20 °C
Electro-motive force	2.26	2.46	2.65	V	20 °C, 3000 rpm