

6W Warm White Led Module WW6R49*7

Features: Applications:

· Single Color.	· Reading Lamp.
· Illuminant Color : White.	· Street Lamp.
· Emission angle:120Deg.	· LED Backlight.
· Linear Packaging Design.	· Energy Saving Lamp.
· High Efficiency.	· Decorative and Entertainment Lighting.
· Low Power Consumption.	· Indoor and Outdoor Commercial Lighting.
· Long Operating Lifespan.	
· Easy Installation with Screws.	
· High Heat dissipation Efficiency.	

Package

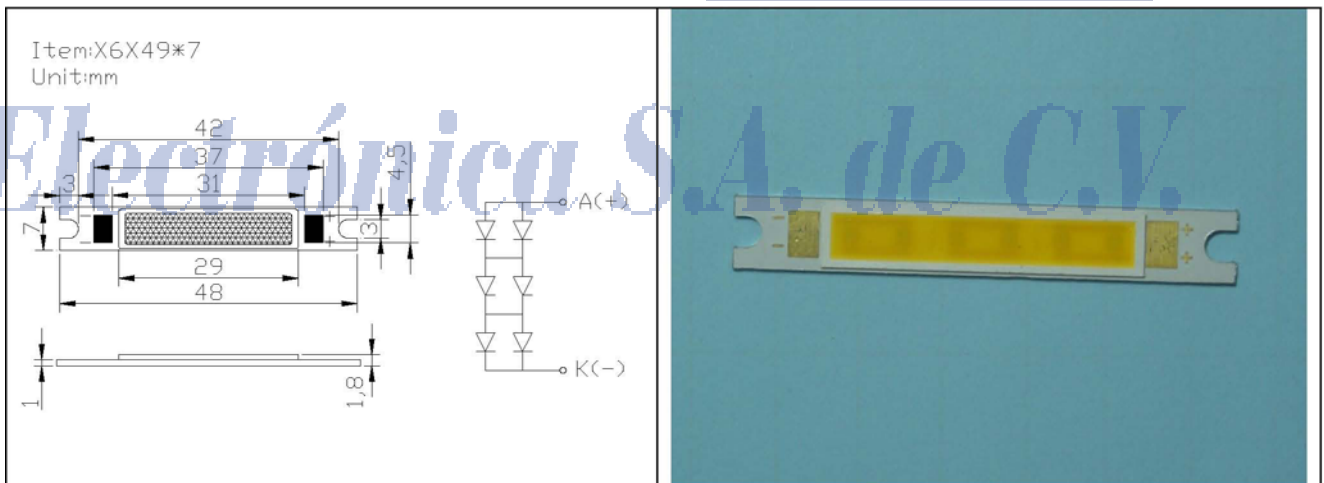

Product Dimension Notes:

1. 1. All dimensions are measured in mm.
2. 2. Tolerance: +0.2.
3. 3. The temperature of Aluminum PCB dose not exceed 55°C.

20090313

Absolute Maximum Rating at T_A=25°C

Absolute Maximum Rating For Product

Parameter	Symbol	Rating(White)	Unit
DC Forward current	IF	700	mA
Peak pulse current	IFM	1000	mA
Reverse voltage	VR	5	V
ESD Sensitivity	VB	500	V
Power dissipation	PD	6	W
Junction temperature	T _j	125	°C
Operating temperature	T _{opr}	-30~+100	°C
Storage temperature	T _{stg}	-40~+120	°C
Soldering temperature	T _{sol}	260	°C
Manual Soldering time at 260°C(Max)		5	sec

Electro-Optical Characteristics (T_a = 25°C)

Parameter Radiant	Test Current	Symbol	Min	Typ.	Max	Unit
Color Temperature Characteristics	IF=700mA	CCT	2500	3100	3500	K
Luminous Flux Characteristics	IF=700mA	∅	390	420		LM
Emission Angle Characteristics	IF=700mA	2 θ 1/2		110		Deg
Electrical Characteristics	IF=700mA	VF		10	12	V

Description

Dimension (L*W*H) mm	Chip		Colloid Type	Material
	Emitter color			
49*7*1.8	White	InGaN	Yellow Diffuse	

Typical Electro-Optical Characteristics Curve:

Forward Voltage vs Forward Current

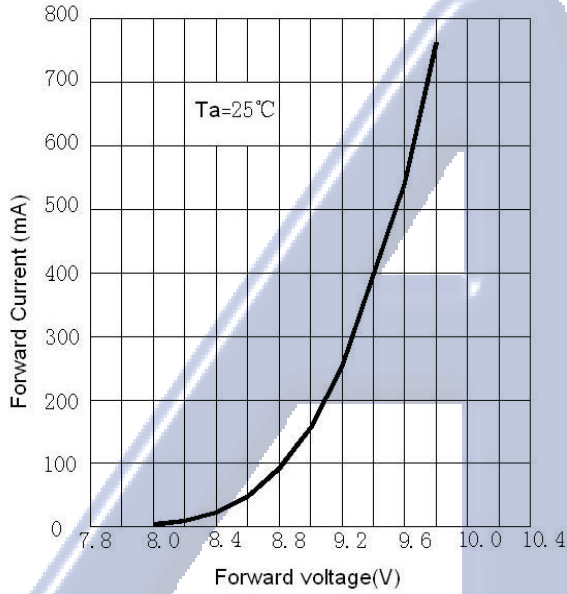

Forward Current vs Luminous Intensity

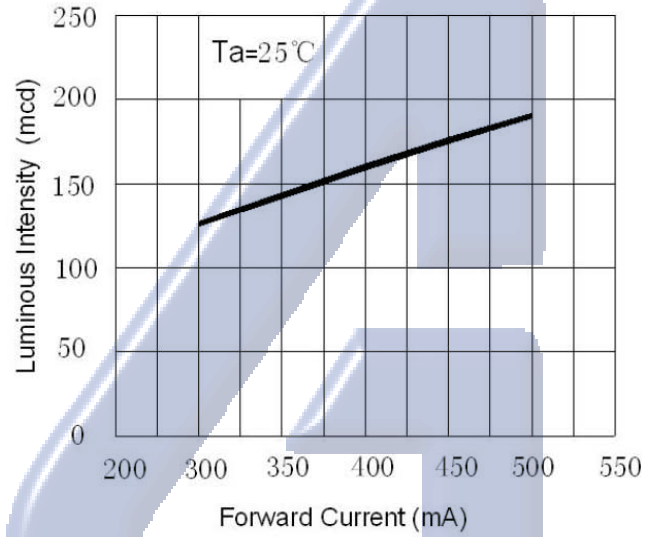

Spatial Distribution

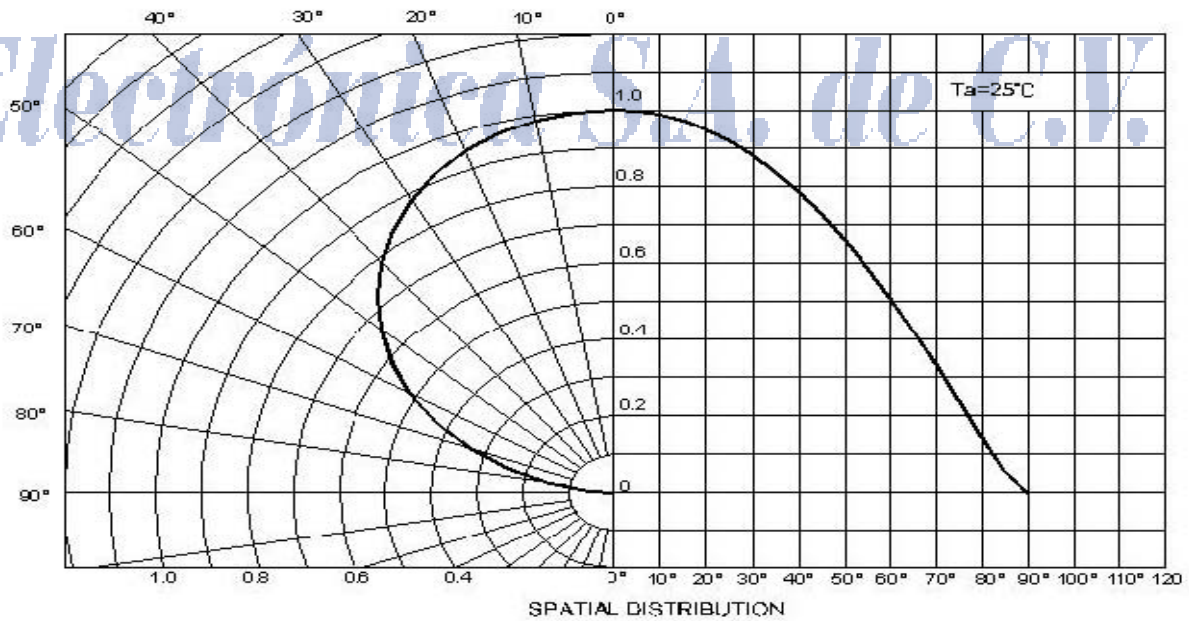

Product Thermal Application Information

When assembling on PCB or heatsink carrier, thermal grease should be evenly speeded with a thickness <math><100\mu\text{m}</math>.

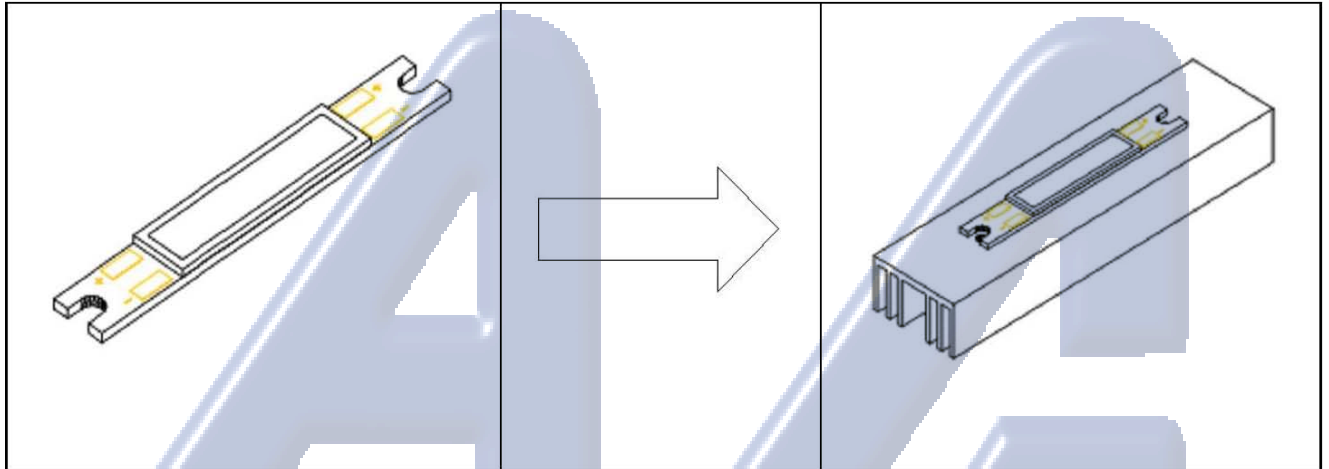

Heatsink application

Product Packaging information (Unit:mm)

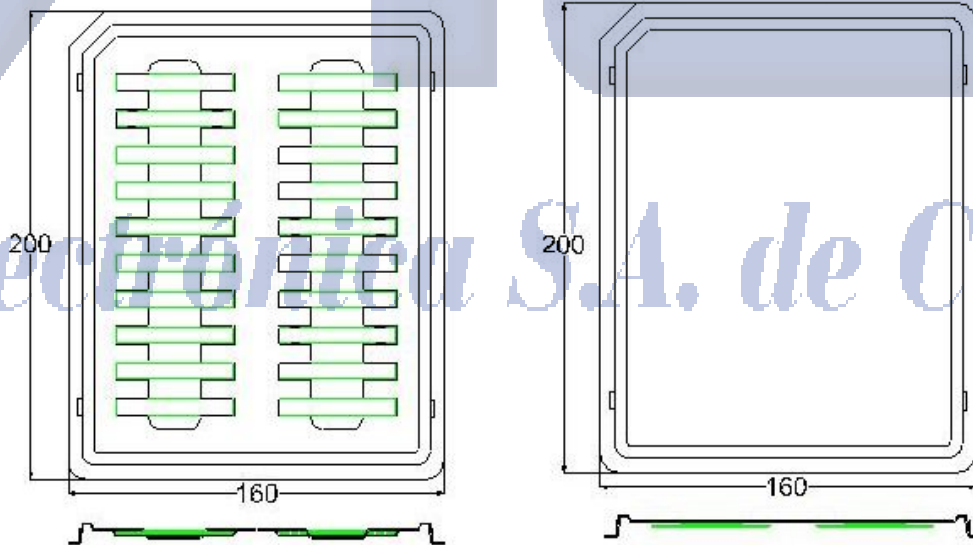

Tray Package dimensions

Note:

1. There are 20pcs emitters in a tray package.
2. Package storage condition will be limited temperature 20~30°C RH 40%~55%.